

USER GUIDE FOR

DATALINE-X™

COMPASS

Stowe Marine Ltd.

www.stowemarine.com

Tel +44(0)1590 610071

Dataline-X Compass Manual, Part Number 06267SM, Issue 2, Dec 1995.

Warning

The equipment to which this manual applies must only be used for the purpose for which it was designed. Improper use or maintenance may cause damage to the equipment and/or injury to personnel. The user must be familiar with the contents of the manual before attempting to operate or work on the equipment.

Simrad Ltd disclaims any responsibility for damage or injury caused by improper installation, use or maintenance of the equipment.

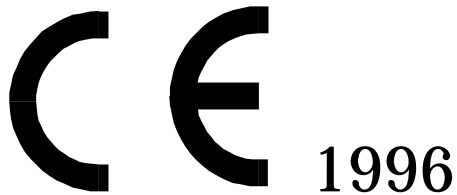

©Simrad Ltd 1996

The information contained within this document remains the sole property of Simrad Ltd. It must not be reproduced in whole or in part, except under an agreement with the consent in writing of Simrad Ltd.

CONTENTS

Part 1	Introduction
Part 2	Operation
Part 3	Installation
Part 4	Setting Up
Part 5	Fault Finding
Part 6	Maintenance
Appendix A	Received NMEA 0183 Messages

CONTENTS

- 1.1 The Dataline-X System
- 1.2 Dataline-X COMPASS Specification
- 1.3 Dataline Heading Sensor Specification
- 1.4 Robertson RFC250 Heading Sensor Specification

1.1 The Dataline-X System

The Dataline-X System, as its name implies, uses a single cable to carry both power and data around the vessel to each instrument. This is done using a NMEA 0183 serial digital communication link, which is an established industry standard. Because of this, instruments from other manufacturers may be interfaced to the Dataline-X System - assuming that they have a NMEA output or input.

This User Guide describes the Navigation System Repeater digital display, known as **Dataline-X COMPASS**, used within the Dataline-X System.

This User Guide also describes the installation and use of the **Dataline HEADING SENSOR** and the **Robertson RFC250 HEADING SENSOR** with the **COMPASS** display.

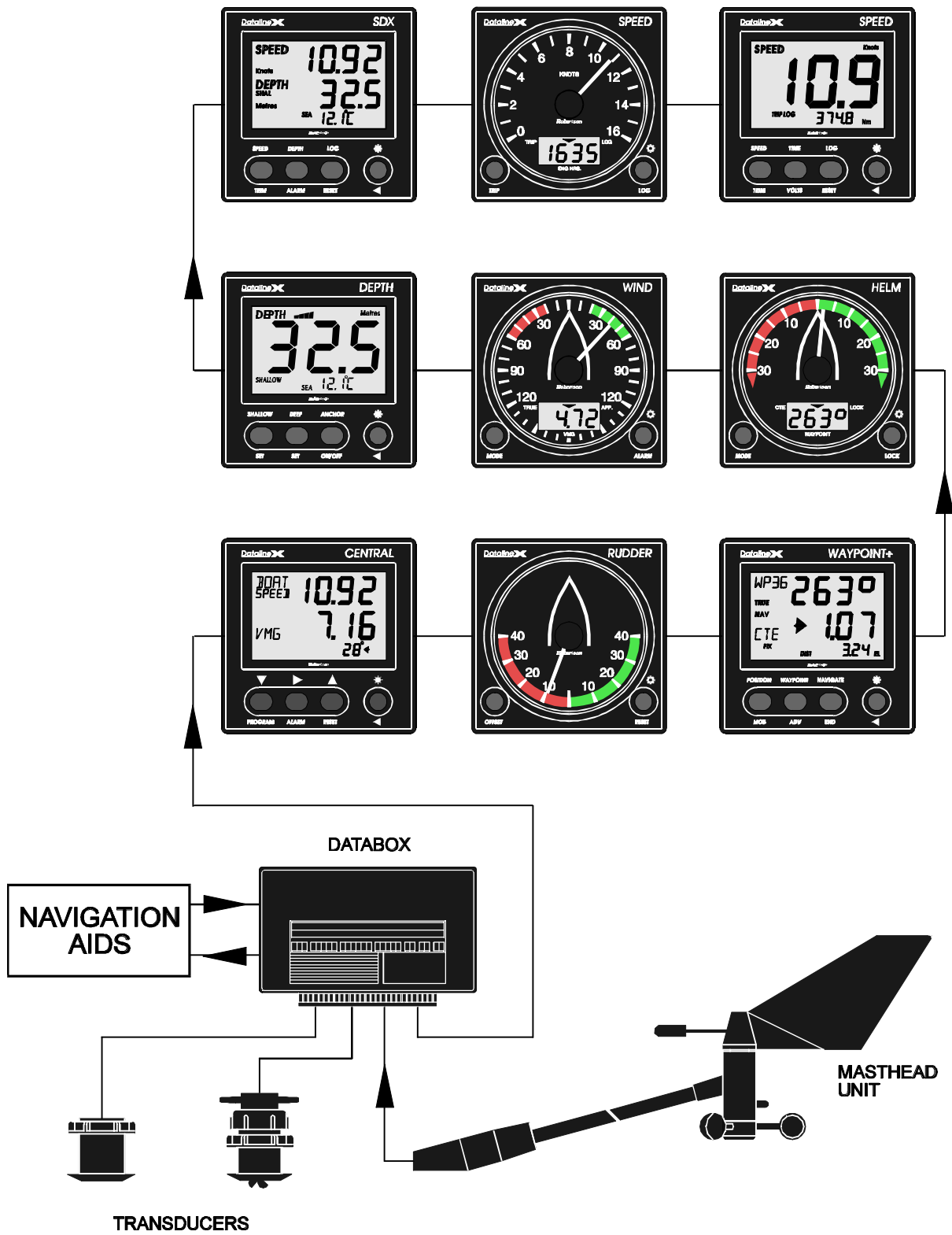

Figure 1.1 - Dataline-X System Diagram

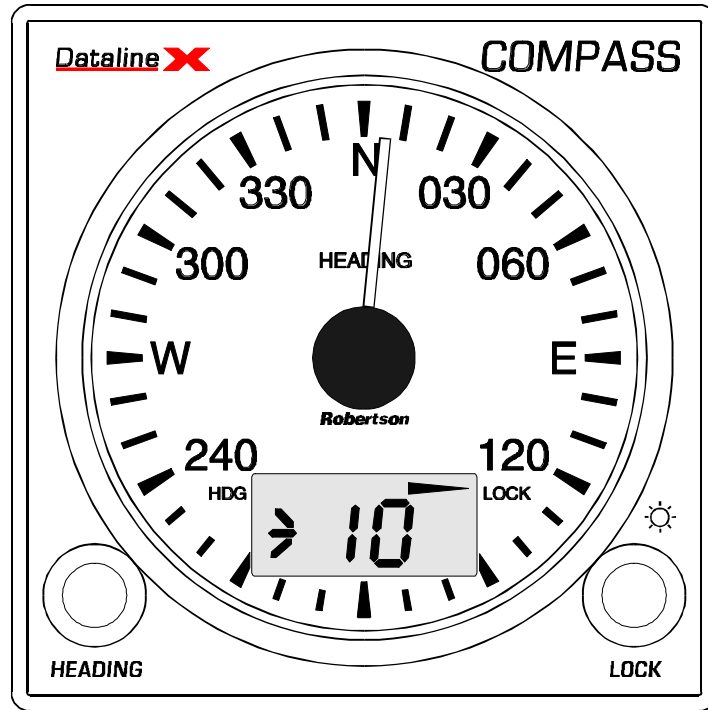

Figure 1.2 - Dataline-X COMPASS Instrument

1.2 Dataline-X COMPASS SpecificationHeading Functions

Heading Display (Digital)	0 to 359°
Heading Precision	1°
Heading Reference	True or Magnetic North (See Note 2.)

Locked Course Functions

Locked Course Display	(Digital)0 to 359°
Locked Course Precision	1°
Off Course Precision	1°
Off Course Reference	Heading

Additional Functions

Compass Auto-Swing Calibration(With Dataline Heading Sensor)	
Calibration Facility	
Display Backlighting Levels	Seven levels plus Off
Display Backlighting Colours	Three colours, (Red, Green, Yellow)
Display Backlighting Control	Two independent lighting banks.

General

Power Requirement	10 to 16V, 70 mA, (100 mA max with lighting)
Size	110 x 110 x 18 mm (above panel)
Mounting Hole Size	50 mm (2 inches)
Total Depth Below Panel Front	32 mm
Weight	210 grams
Environmental Rating	IP65
Temperature Range	0°C to 70°C

Alternative Transducers

If any of the system transducers are not fitted to the Databox, but there is alternative heading or course NMEA data being transmitted from another sensor to the Databox, then this alternative data will be used.

Notes:

1. Values and functions given relate to the display; the heading sensor installed will determine the actual values and functions.
2. All headings and bearings may be referenced to either True or Magnetic North. If True North is selected, and True data is not directly available then the local magnetic variation may be entered (or received from a suitable Radio Navigator via NMEA).
3. The battery voltage range is dependent on the power supply voltages supplied to the Databox - i.e., the 12 volt Databox will measure over the range 10V to 16V, while the 24 volt Databox will measure over the range 20V to 30V.

1.3 Dataline Heading Sensor Specification

Power Requirement	10.6 to 32V, 70 mA
Size (Overall)	120 x 193 x 83 mm
Mounting Centres	130mm
Weight	700 grams
Cable Length	7m
Environmental Rating	IP55
Compass Safe Distance	Grade 1 (0.5 inch) = 1220mm Grade 2 (1 inch) = 1220mm
Resolution	1 degree
NMEA Data Transmitted	No Standard Messages.

1.4 Robertson RFC250 Heading Sensor Specification

Power Requirement	
Size (Overall)	126mm x 160mm diameter
Mounting Centres	140mm radius
Weight	700 grams
Cable Length	15m
Resolution	1 degree
NMEA Data Transmitted	HCHDM, HCUHW

CONTENTS

2.1	General Description
2.1.1	The Dialplate
2.1.2	The LCD Display
2.1.3	The Buttons
2.2	Powering Up
2.3	The Heading and Locked Course Displays
2.3.1	The Heading Display
2.3.2	The Locked Course Display
2.3.3	Locking and Changing the Set Course
2.4	To Set The Display Backlighting
2.5	Heading Sensor Error Displays
2.6	Demonstration Mode

2.1 General Description

The display is divided into two sections, the pointer, and the LCD.

2.1.1 The Dialplate

The dialplate is printed with a scale which shows degrees and N, S, E, W. (See Part 4). The pointer always shows True or Magnetic Heading.

2.1.2 The LCD Display

There are two arrows at the top of the LCD which show which data is being displayed at any one time. The right arrow points to **LOCK** on the dialplate for 'Locked Course Mode', the left arrow points to **HEADING** on the dialplate.

The data indicated by the LCD in each mode is as below:

Mode	Data
Heading Mode	Heading
Locked Course Mode	Off Course Error

2.1.3 The Buttons

The word below the button indicates the main function for that button.

The HEADING button changes the current display mode to heading.

The LOCK button acts in heading and locked course modes to re-lock the locked course and enable it to be changed. If this button is held down it sets the lighting level.

When a function has been selected, a BEEP will be heard to confirm correct operation.

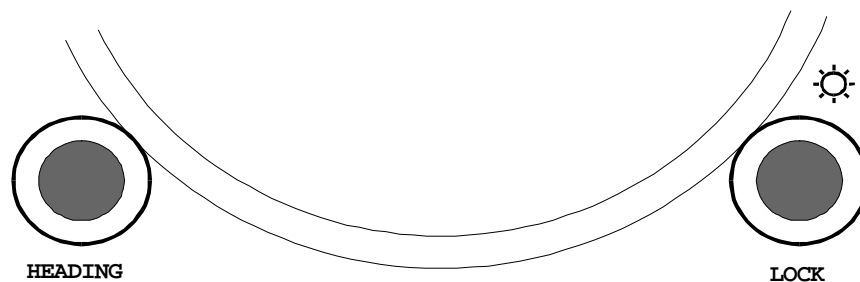

Figure 2.1 - The Buttons

2.2 Powering Up

When powering up the instrument, it will beep, the pointer will move to the top of the display, and will show all the LCD segments for one second.

The display will then show the current heading if it is available.

2.3 The Heading and Locked Course Displays

These two displays will be available in all systems.

2.3.1 The Heading Display

The Heading Display is the first display that is shown after power up. It simply shows the present heading on the LCD, followed by a degrees sign, '°', and with the left LCD arrow lit. The pointer also shows the present heading.

When using the HEADING push-button to cycle around the display menu the Heading Mode is indicated by the symbol 'HdG', for heading.

Notes:

1. The heading may be referenced to either Magnetic or True North. If only one type of data is available, and the other data is required then the local magnetic variation may be entered, or it may be read in from a Radio Navigator if one is fitted, and the correct NMEA message is transmitted by it. This may for instance enable the display of True data when only a magnetic referenced heading sensor is available.
2. If no data at all is available this display will be the only one that is shown, and it will show four dashes, '----'.

2.3.2 The Locked Course Display

From the Heading Mode a single press of the LOCK push-button will cause the display to show 'LOCK' for three seconds, and then to enter Locked Course Mode. This will set the present heading as the locked course. Alternatively the HEADING push-button may be pressed to leave Locked Course Mode, and this will leave the locked course unchanged.

The Locked Course display shows the Locked Course on the LCD, followed by a degrees sign, '°', and with the right LCD arrow lit. The pointer shows the deviation of the vessel from the locked course. If the LCD shows >XXX then the vessel needs to turn to starboard to steer back onto the correct course. The opposite applies if the vessel is off course to port.

Note: If the heading data ceases to be available the pointer will return to the centre position, and the LCD will show four dashes, '----'.

2.3.3 Locking and Changing the Set Course

Whenever the LOCK push-button is pressed in Locked Course Mode the Locked Course will be set to the present heading.

If this is the course that is required then it can simply be left as it is. However, for three seconds after the LOCK push-button has been pressed the degree sign at the right of the LCD is flashed, and during this time if either of the two buttons are pressed it will change the locked course in that direction. Small changes may be made by individual presses of the buttons, but if a large course change is required then the buttons may be held down. Every time that either of the buttons is pressed the three second time-out is started again, until the correct course is set.

The Locked Course is also set to the present heading if the LOCK push-button is pressed to enter Locked Course Mode from Heading Mode.

2.4 To Set Display Backlighting

1. Press the LOCK button and hold. The display backlighting will change from 0 to level 7, then level 6, then level 5, and so on to level 0. If the button is still held, the level will then increase back to 7 again.
2. At the desired display backlighting, release the LOCK button. This will set the lighting on ALL displays on the Dataline-X system, which are in the same Lighting Bank. The Dataline-X system has two lighting banks, so that the internal lighting on a power boat may be set differently to that on the flybridge, or the cockpit lighting may be set differently to the chart table or mast display lighting on a yacht. All displays are supplied set to bank 1. (See Part 4 for the bank set-up information.).

Notes:

1. The lighting may not be set from the COMPASS display when it is in Locked Course Mode, instead the lighting should be set from any other display in the system.
2. If the COMPASS is in Heading Mode when the push-button is pressed then it will return to Heading Mode after setting the lighting, it will not go into Locked Course Mode.
3. On some Dataline Systems (not Dataline-X) only lighting levels 0, 3, 5 and 7 are available.

2.5 Heading Sensor Error Displays

If the COMPASS display is used with a Dataline Heading sensor then a Compass Error display may be seen if there is a fault with the sensor.

This display will be shown instead of the normal display, and can be canceled by pressing either button. If an error is seen then the heading sensor should not be used for navigation until the error has been corrected.

The error messages consist of a display of 'Err' and a number which identifies the nature of the error, as below:

- 'Err4' = Memory Error, contact your dealer for advice.
- 'Err6' = Battery Voltage is below 11 Volts.

If any other errors are seen (and the heading sensor is not in auto deviation compensation mode - See Part 4) then consult your dealer for advice.

2.6 Demonstration Mode

The Demonstration Mode allows the user to familiarize himself/herself with all the functions of the instrument with the device removed from the system. Demonstration software within the instrument produces realistic values for the display.

A +12V power supply will be required to be connected as follows:

- 0V to the BLACK (far right) terminal.
- +12V to the RED (far left) terminal.

To enter the Demonstration Mode, press the LOCK button whilst applying power to the instrument.

To leave the Demonstration Mode, switch off and re-apply power.

Notes:

1. The display will leave demonstration mode if any data is received.
2. The display can be set to automatically enter 'Shop' demonstration mode every time it is powered up. (See Part 4 for further details.)

CONTENTS

- 3.1 General
- 3.2 Installation of the COMPASS Display
- 3.3 Installation of the Dataline Heading Sensor
- 3.4 Installation of the RFC250 Heading Sensor
- 3.5 Compass System Wiring
- 3.6 Choosing the Cable Routes
- 3.7 Securing the Cable

3.1 General

The instrument head is fully waterproof and can, therefore, be installed on deck or below. The connections should be protected from water penetration and should, if possible, allow rear access to remove the desiccant pack, if required. The position selected should, in the first instance, meet the requirements of the helmsman, or crew.

The selected surface for the instrument must be flat and even to within 0.5mm.

Before installation, note the Serial Number and keep it in a safe place.

Great care should be taken when deciding on the location for the heading sensor; it should be mounted away from areas of magnetic interference, and as close the vessel's centre of pitch and roll, as possible. The mounting should also be solid and free of vibration. On steel vessels, the sensor should be mounted on the mast, approximately one to three metres from the main structure; although in other cases, do not install the sensor at the flybridge or the mast as the display reading will swing as the boat rolls.

As a guide to minimising magnetic interference, the sensor should be a minimum of:

ONE metre from:

Radios and loud-speakers

RDF Instruments

Other compasses

Cables carrying more than 1/2 Amp

Depth sounders, etc.

TWO metres from:

Engines / electric motors

Large masses of soft iron, e.g., keels

THREE metres from:

Radar magnetrons.

It is possible to use a small hand-held magnetic compass to check the mounting location. Move the compass in a horizontal circle of approximately 30 cm (1 ft) radius around the desired mounting location. Be sure that the lubber line is parallel to the midships line, and observe any heading - change from the first noted reading. Not more than 50 deflection should be observed. Repeat the same circle test, this time in a vertical circle. Little or no compass card deflection should be observed. This check should be done with any nearby equipment powered, and cables carrying their normal current.

The Dataline Heading sensor requires a mounting surface which is vertical,

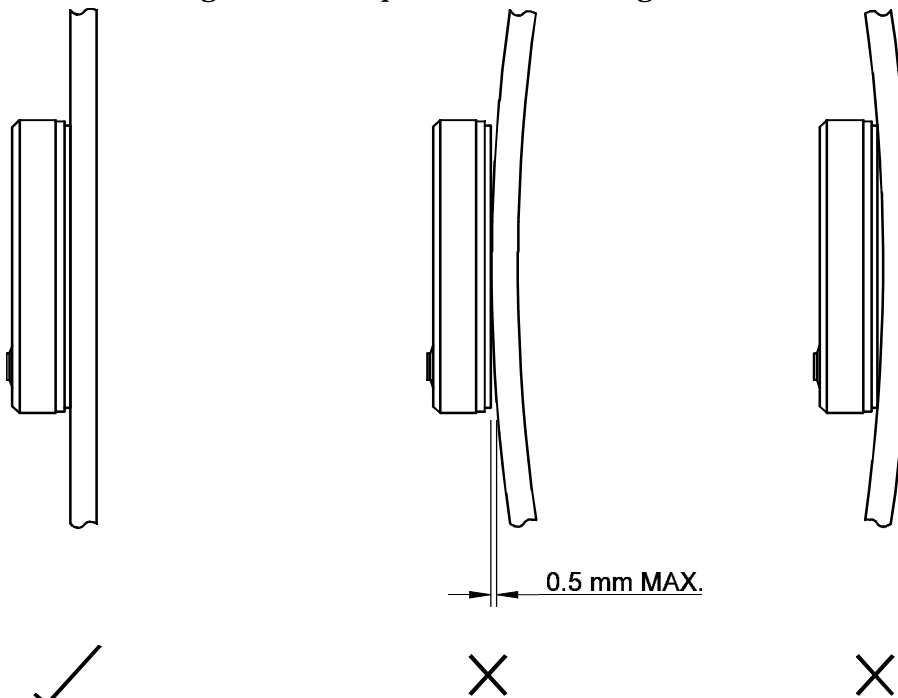

and facing forwards. The RFC250 sensor requires a horizontal mounting surface.

Figure 3.1 - Installation

3.2 Installation of the COMPASS Display

1. Carefully position the self-adhesive template provided on the surface where the instrument is to be mounted.
2. Drill a small pilot hole first, and then check the location on the other side of the panel or bulkhead to confirm suitability.
3. Open out the pilot hole to 50 mm (2 ins.) using a cutter in a hand-held brace, or electric drill.
4. Drill the four fixing holes using a 2.5 mm (3.32 ins.) drill.

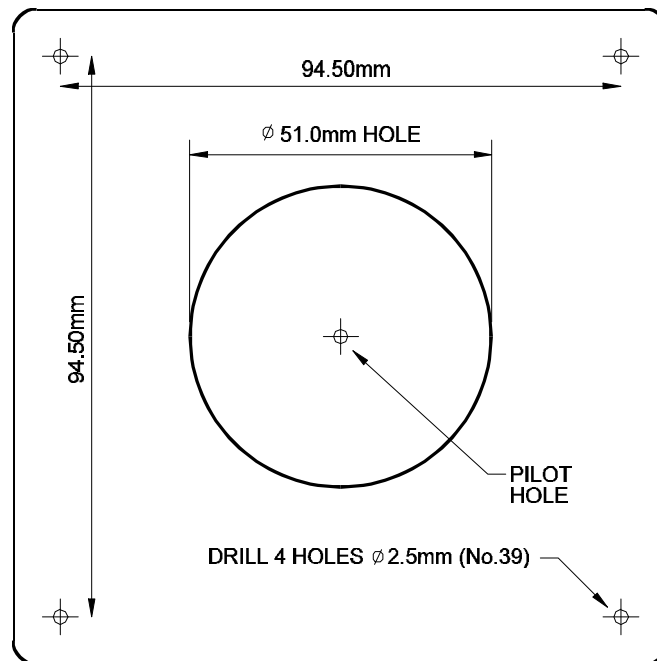

Figure 3.2 - Mounting Details (Not To Scale)

1. The instrument should next be wired into the system. The wiring should be carried out as in the 'Choosing the Cable Routes' and 'Securing the Cable' Sections below.
 - a. If the instrument is being connected to a Dataline-X system, then connect it to the Dataline wire. This can normally be done simply by using the 'Dataplug' connector and cable supplied to connect the display to the Databox or to any adjacent display.

If the cable routing cannot be made with the Dataplug connector attached, then simply disconnect it from the cable. The cable may then be run through holes of down to 6 mm (0.25 ins.) diameter before reconnecting the Dataplug connector, making sure that the colours are correctly wired to the terminals. The correct positions for the different coloured wires are shown on the rear label of the instrument.

- b. If the instrument is being connected directly to a Dataline or Robertson RFC 250 Heading sensor then see the 'Wiring the Compass System' Section below.
- c. If the instrument is being connected directly to a Robertson AP3000 or AP300 Autopilot Junction Box, then the connections are as below:

- Red = 'Dataline' Red.
- White = 'Dataline' Wht.
- Brown = 'Dataline' Brn.
- Green = 'Dataline' Grn.
- Black = 'Dataline' Blk.

- d. If the instrument is being connected directly to a Dataline Chart or Multi-Chart Chart Plotter, then the connections are as below:

- Red = +12V Power In (Fused 1A).
- White = Chart I/O Cable Yellow.
- Brown = Not Connected.
- Green = Chart I/O Cable Green AND Grey.
- Black = 0V Power In.

- e. If the instrument is being connected to a Radio Navigator, or to another instrument system then the connections are as below:

- Red = +12V Power In (Fused 1A).
- White = NMEA Signal In (A / + / Positive).
- Brown = Not Connected.
- Green = NMEA Reference In (B / - / Negative).
- Black = 0V Power In.

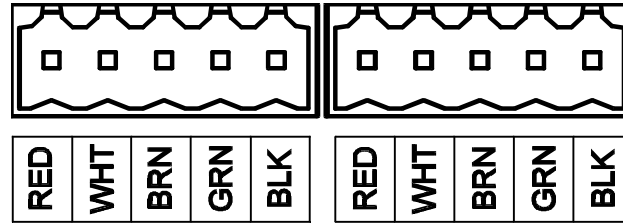

Figure 3.3 - Electrical Connections to the Display

6. Check that the instrument functions correctly.
7. Temporarily disconnect the Dataplug connectors and coat the terminals and wires with silicone grease or petroleum jelly. These products will not harm the instrument.
8. Make sure the 'dovetail' lugs are free from grease and securely located into the rear of the instrument when replacing the Dataplugs.
9. Secure the instrument using the four, No 4 self-tapping screws provided. Ensure that the sealing gasket is correctly located.
10. Replace the front cover, the installation of the instrument is complete.

CAUTIONS

DO NOT OVER-TIGHTEN FIXING SCREWS.

DO NOT USE SEALING COMPOUND ON THE INSTRUMENT BACK.

DO NOT USE WD40 OR ANY SOLVENT ON ANY PART OF THE INSTRUMENT.

3.3 Installation of the Dataline Heading Sensor

1. Find a suitable vertical mounting surface, considering the points detailed above.
2. Remove the fixing bracket from the sensor using a 4mm Hexagon key.
3. Attach the bracket to the mounting surface using brass or stainless steel screws, DO NOT use ordinary steel screws. Note that the sensor must be mounted vertically with the cable exit at the bottom, and that the mounting surface must be facing forwards.

4. Release the transit screw on the sensor. This is found at the base of the sensor towards the rear. Unscrew the screw 10 full turns to allow full movement of the sensor assembly. If the sensor is being mounted externally then the screw should be removed and shortened by 10mm before refitting tightly.
5. Mount the sensor on its bracket, and wire in to the rest of the system. See the Wiring section below for details of different systems connections.
6. Check that the system is working correctly, and carry out the Automatic Deviation Compensation Procedure. (See Part 4).

3.4 Installation of the RFC250 Heading Sensor

1. Find a suitable horizontal mounting surface, considering the points detailed above.
2. Position the sensor with the arrow on its top aligned with the fore-aft line of the vessel, pointing forwards.
3. Mark for the fixing screws in the centre of the three slots, and drill the three holes for the fixings to be used. Note that the sensor must be mounted horizontally and must not be mounted upside down. If only vertical bulkheads are available then a right angle bracket must be used as a mounting platform.
4. Attach the bracket to the mounting surface using brass or stainless steel screws, DO NOT use ordinary steel screws. Initially only tighten the fixings loosely, as the slots will allow the sensor to be slightly rotated for alignment during the sea trial. The screws should subsequently be tightened.
5. Wire the sensor in to the rest of the system. See the Wiring section for details of different systems connections.
6. Check that the system is working correctly, and carry out the Automatic Deviation Compensation Procedure. (See Part 4).

3.5 Compass System Wiring

A Dataline Heading sensor is connected directly to a display as below:

<u>Display Terminal</u>	<u>Sensor Wire</u>	<u>Function</u>
Red	Red	+12V Power In (Fused 1A)
White	Blue	NMEA Heading Data
Brown	White	NMEA Calibration Data to Sensor
Green	Black	NMEA Reference (0V Power In)
Black	Black	0V Power In

A Dataline Heading sensor is connected to a Databox as below:

<u>Databox Terminal</u>	<u>Sensor Wire</u>	<u>Function</u>
Dataline Red	Red	+12V Power In
Dataline Brn	White	NMEA Calibration Data to Sensor
Dataline Blk	Black	0V Power In
Compass +	Blue	NMEA Heading Data
Compass -	Black	NMEA Reference (0V Power In)

A Robertson RFC250 Heading sensor is connected directly to a display as below:

<u>Display Terminal</u>	<u>Sensor Wire</u>	<u>Function</u>
Red	White	+12V Power In (Fused 1A)
White	Blue	NMEA Heading Data
Brown		No Connection
Green	Brown	NMEA Reference
Black	Black	0V Power In
-	Red	No Connection, Isolate
-	Green	No Connection, Isolate
-	Violet	No Connection, Isolate

- Yellow No Connection, Isolate

A Robertson RFC250 Heading sensor is connected to a Databox as below:

<u>Databox Terminal</u>	<u>Sensor Wire</u>	<u>Function</u>
Dataline Red	White	+12V Power In
Dataline Blk	Black	0V Power In
Compass +	Blue	NMEA Heading Data
Compass -	Brown	NMEA Reference
-	Red	No Connection, Isolate
-	Green	No Connection, Isolate
-	Violet	No Connection, Isolate
-	Yellow	No Connection, Isolate

3.6 Choosing the Cable Routes

After you have decided on the system and started to mount the components of the Dataline-X System, the next step in the installation process is to route the cables between the various parts of the system and to the power supply. When routing the cables, choose the most direct paths while avoiding the following hazards:

- Sharp bends or kinks in the cable
- Hot surfaces (exhaust manifolds or cooking equipment)
- Rotating or reciprocating equipment
- Sharp or abrasive surfaces
- Door and window jambs
- Corrosive fluids or gases

3.7 Securing the Cable

After the ideal cable routing has been established, use tie-wraps, 'P' - clips or other fixings to secure the cables along the routings.

Notes:

1. Install protection for the cable jackets where the cables pass through bulkheads, or past sharp edges. This will prevent the cables from chafing.
2. Securing the cable near to the terminals serves as a strain relief.

-
3. Secure the cable ends with enough slack to allow for easy connection.
 4. Cut any spare wire ends to an appropriate length.

CONTENTS

- 4.1 System Calibration
- 4.2 Calibration Mode
- 4.3 Lighting Colour Selection
- 4.4 Lighting Bank Selection
- 4.5 LCD Contrast Setting
- 4.6 True / Magnetic Headings and Bearings Selection
- 4.7 Magnetic Variation Entry
- 4.8 Compass Auto-Deviation Compensation
 - 4.8.1 Compass Auto-Deviation Compensation - With the Dataline Heading Sensor
 - 4.8.2 Compass Auto-Deviation Compensation - With the Robertson RFC250 Heading Sensor
- 4.9 Test Mode Entry Screen
- 4.10 Shop Demo Mode Setting
- 4.11 Leaving Calibration Mode

4.1 System Calibration

After installation, the system may be calibrated to take into account the physical position of and type of transducers installed. Additionally, such things as display units and precision may be selected.

4.2 Calibration Mode

To enter Calibration Mode:

1. Press both buttons together, and hold for more than 3 seconds, until 'rEd', 'Grn', or 'YEL' is shown on the display.
2. For each successive press of the LOCK button, the display will step through the calibration menu. To step through backwards, press the HEADING button.
3. The menu function may be changed immediately by pressing both buttons together, or this may cause the value to flash, depending on the function.

4. The HEADING and LOCK buttons may be used to decrement or increment values, which are flashing. When the value is correct, press both buttons together again to save it.
5. Selecting the Calibration Mode End Screen and pressing both buttons together will return the instrument to its normal working mode.

The following calibration functions are available:

- Lighting Colour (select Yellow, Red or Green)
- Lighting Bank (select Bank One or Bank Two)*
- LCD Contrast (select Level 1 or Level 2)
- Headings and Bearings Reference (select Magnetic or True North)
- Magnetic Variation Entry (value entry, OFF, or $\pm 180^\circ$)
- Automatic Compass Deviation Compensation (select or deselect)
- Test Mode entry screen (select, On, Off)
- Shop Demo Mode Selection (select On, Off)

The options marked with '*' perform no function if the display is not part of the Dataline-X system.

4.3 Lighting Colour Selection

This function enables the colour of the backlighting on the display to be set to Yellow, Red, or Green. This is independent of all other displays.

1. Press both buttons together, and hold for more than 3 seconds.
2. The display should indicate the current lighting colour as either 'rEd', 'Grn', or 'YEL', and will light to show this.
3. Press both buttons together to the desired colour, 'rEd' (Red), 'Grn' (Green) or 'YEL' (Yellow).
4. Return to the main display by pressing the HEADING button once to select the Calibration Mode End Screen, and then pressing both buttons together.

4.4 Lighting Bank Selection

The Dataline-X instrument system can have two separate banks of instruments. Setting the lighting level on one display will set all the other displays in that bank to the same level, but will not effect any displays in the other bank. For instance, the lighting level can be independently controlled for:

1. The cockpit and chart table displays of a yacht.
2. The cockpit and mast displays on a yacht.
3. The cabin and flybridge of a motor yacht.

This is independent of the display colour, so that displays in the same bank may have different colours if desired.

1. Press both buttons together, and hold for more than 3 seconds, until 'rEd', 'Grn', or 'YEL' is shown on the display.
2. Press the LOCK button once until the LCD indicates '-1-' (or '-2-').
3. Select the required lighting bank, either 1 or 2, by pressing both buttons together.
4. Return to the main display by pressing the HEADING button twice to select the Calibration Mode End Screen, and then pressing both buttons together.

4.5 LCD Contrast Setting

The LCD on Dataline-X Series instruments can be set to one of two or more contrast levels to best suit the viewing angle of the particular installation. This display has two contrast levels.

The default level (level 2) is suitable for a wide range of viewing angles and will probably not require alteration. However, if viewing the display from above, the contrast level may be lowered to level 1 to reduce the 'ghosting' of the parts of the display which are turned off. The lighting is illuminated when setting the contrast to highlight the display.

1. Press both buttons together, and hold for more than 3 seconds, until 'rEd', 'Grn', or 'YEL' is shown on the display.
2. Press the LOCK button twice until the LCD indicates the current contrast level as 'LCd2' (or 'LCd1').

-
3. Select the required LCD contrast level, either 1 or 2, by pressing both buttons together.
 4. Return to the main display by pressing the HEADING button three times to select the Calibration Mode End Screen, and then pressing both buttons together.

4.6 True / Magnetic Headings and Bearings Selection

The displayed heading and bearings may be set to reference either Magnetic or True North.

1. Press both buttons together, and hold for more than 3 seconds, until 'rEd', 'Grn', or 'YEL' is shown on the display.
2. Press the LOCK push-button three times until the LCD indicates the current selection as (a distorted) 'MAG' (or 'truE').
3. Select the required heading reference, either Magnetic or True, by pressing both buttons together.
4. Return to the main display by pressing the HEADING push-button four times to select the Calibration Mode End Screen, and then pressing both buttons together.

4.7 Magnetic Variation Entry

As a default the Magnetic Variation compensation on the COMPASS is turned Off, and it will only read messages that contain the correct data, either Magnetic or True. This is the 'safest' setting because an incorrect Variation setting will not give false or erratic data. However in some instances some of the displays may not be available because the data is not in the correct format. For instance, True Headings may be required, while the heading sensor is a fluxgate compass giving Magnetic data, or the Waypoint Display may not be available because the heading is Magnetic, but the only Waypoint Bearings available are True.

Therefore the COMPASS can have the local magnetic variation entered so that it can change incoming headings or bearings from Magnetic to True, or vice versa.

1. Press both buttons together, and hold for more than 3 seconds, until 'rEd', 'Grn', or 'YEL' is shown on the display.
2. Press the LOCK button four times until the LCD indicates 'VAR?'
3. Press both buttons together to start to set the variation value, the current value will be shown flashing. If the variation compensation is turned Off it will show 'OFF'. The variation is turned off by setting it to between -1° and $+1^{\circ}$
4. Increase the variation value (or turn it on at $+1^{\circ}$ if it is off) using the LOCK button.
5. Decrease the variation value (or turn it on at -1° if it is off) using the HEADING button.

6. Press both buttons together to save the variation value.
7. Return to the main display by pressing the HEADING push-button five times to select the Calibration Mode End Screen, and then pressing both buttons together.

4.8 Compass Auto-Deviation Compensation

The Calibration process must be performed after installation of the system, after any movement, additions, or removals of metal objects from the vicinity of the sensor, and also if the vessel is moved to a latitude of more than 20° from where the last calibration was carried out.

Calibration of the Dataline Heading sensor is controlled by the COMPASS display, whereas calibration of the Robertson RFC250 Heading sensor is done automatically by the sensor. Both processes are detailed below.

4.8.1 Compass Auto-Deviation Compensation - With the Dataline Heading Sensor

In order to compensate the Dataline Heading sensor first select the auto deviation compensation screen in the Calibration mode, and then command the heading sensor to perform its Automatic Deviation Correction Calculation. When the sensor has started the process the vessel should be slowly steered in a number of circles until the sensor signals that the process has been finished. This will normally take up to four rotations, and is best performed in good conditions, with a calm sea.

1. Press both buttons together, and hold for more than 3 seconds, until 'rEd', 'Grn', or 'YEL' is shown on the display.
2. Press the HEADING push-button four times until the LCD shows 'HdG' and a number or letter. The number or letter indicates the status of the heading sensor, as below:

'HdG0' = Heading sensor is Not Deviation Compensated.

'HdGc' = The Heading sensor is already Compensated.

'HdG4' = Memory Error, contact your dealer for advice.

'HdG6' = Battery Voltage is below 11 Volts.

3. If any other number is seen then this is another error, so consult your dealer for advice.
4. If the LCD shows 'HdGc' then the heading sensor is already compensated. However if it needs to be compensated again due to movement of metal or magnetic objects in its vicinity then press both buttons. The LCD will show 'HdG', and then after a short time it

should show 'HdG0' to indicate that the sensor is no longer compensated and is ready to be compensated again.

5. If the LCD shows 'HdG0' then it is not compensated, and is ready to be compensated, so continue with the steps below:
 - a. Place the vessel in a position where it can be swung through a full 360 degrees.
 - b. Align the vessel to approximately 270 degrees. It must not be at a heading of below 180 degrees.
 - c. Press both buttons. The LCD will show 'HdG ', and then after a short time it should change to 'HdGi' to show that the process has been initiated. If it is desired to stop the process press both buttons again.
 - d. Begin swinging the vessel, either by hand or by motoring circles. The rate of rotation is not critical, but about one minute per revolution is suitable. The movement should be smooth, with a minimum of roll and acceleration.
6. During this process the LCD will change to show 'HdGr', indicating that the calibration process is running.
7. If at any time the LCD shows a number after 'HdG' then an error has occurred, as below:
 - 'HdG1' = Upon initiating the procedure the heading was less than 180 degrees, restart the procedure with a heading of approximately 270 degrees.
 - 'HdG2' = The speed of rotation is too slow, restart the procedure making sure that the speed of rotation is faster.
 - 'HdG4' = Memory Error, contact your dealer for advice.
 - 'HdG6' = Battery Voltage is below 11 Volts.
8. If any other number is seen then consult your dealer for advice.
9. After a number of rotations the LCD will change to show 'HdGc', indicating that the calibration is complete.
10. Return to the main display by pressing the LOCK button three times to select the Calibration Mode End Screen, and then pressing both buttons together.

11. If possible check the compass against known compass points. If a constant heading error is found then consult your dealer.

4.8.2 Compass Auto-Deviation Compensation - With the Robertson RFC250 Heading Sensor

The RFC250 Heading sensor is calibrated automatically by performing at least two sequential 360° turns within five minutes of system turn on. This is best performed in good conditions, with a calm sea.

1. Place the vessel in a position able to swing through a full 360°.
2. Align the vessel to approximately 270 degrees. It must not be at a heading of below 180 degrees.
3. Turn the compass system on, If it was already turned on then turn it off, wait a few seconds, and then turn it back on again.
4. Begin swinging the vessel, either by hand or by motoring circles. The rate of rotation is not critical, but about one minute per revolution is suitable. The movement should be smooth, with a minimum of roll and acceleration. The process will be completed when the vessel has swung three times through North.
5. If possible check the compass against known compass points. If a slight constant heading error is found then the heading sensor can be turned to correct this. The sensor should then be checked again.

Notes:

1. Some versions of the RFC250 Heading sensor output the NMEA message that gives the Compass Calibration Status to the COMPASS display.
2. The displays given by these sensors will be as below:

'HdG' = The Auto Deviation Compensation process has not been performed since the last power up.

'HdGc' = The Auto Deviation Compensation process is complete, the heading sensor is Compensated.
3. In this case if Calibration is to be done the boat should be swung within five minutes of power up until the display shows 'HdGc'. 'HdGc' will then be shown until the next time that the sensor is powered down.
4. RFC250 Heading sensors which do not have this feature will always show 'HdG', even when the Calibration process has been successfully completed.

4.9 Test Mode Entry Screen

The Test Mode will test all display functions (See Part 5 for further details).

1. Press both buttons together, and hold for more than 3 seconds, until 'rEd', 'Grn', or 'YEL' is shown on the display.
2. Press the HEADING button three times, until the LCD shows 'tEst'.
3. Press both buttons together to start to set Test Mode On, the current value, 'OFF', will be shown flashing.
4. Select Test Mode On by pressing either button on its own, the LCD will show 'ON' flashing.
5. Press both buttons together to start Test Mode.

If it is decided not to start Test Mode then press either button to change the LCD back to flashing 'OFF', then press both buttons to return to showing 'tEst'. Return to the main display by pressing the LOCK button twice to select the Calibration Mode End Screen, and then pressing both buttons together.

4.10 Shop Demo Mode Setting

The instrument can be set to always power up in demonstration mode by setting 'Shop Demo' Mode On (this function is for use by dealers only).

1. Press both buttons together, and hold for more than 3 seconds, until 'rEd', 'Grn', or 'YEL' is shown on the display.
2. Press the HEADING button twice, until the LCD shows 'SHOP'.
3. Press both buttons together to start to change the Shop Demo mode setting, the current value, 'OFF' (or 'ON'), will be shown flashing.
4. Select Shop Demo Mode On (or Off) by pressing either button on its own, the LCD will show 'ON' (or 'OFF') flashing.
5. Press both buttons together to save the Shop Demo Mode setting.

Return to the main display by pressing the LOCK button once to select the Calibration Mode End Screen, and then pressing both buttons together.

Note: After power up, the instrument will always return from Shop Demo Mode to showing data if any data is received.

4.11 Leaving Calibration Mode

To return to the main display select the Calibration Mode End Screen.

1. From any Calibration Mode menu screen press either button until the LCD shows 'End?'. This is the Calibration Mode End Screen.

-
2. Return to the main display by pressing both buttons together.

CONTENTS

- 5.1 General
- 5.2 Test Mode
- 5.3 Fault Finding Chart

5.1 General

This instrument has been tested before shipment. However, installation conditions and procedures are outside the control of the manufacturer and can sometimes produce faults. The following check list is provided to assist the user in diagnosing such faults and suggests remedial action to be taken. The built in Test Mode will also help diagnose faults. For additional assistance, call your local dealer.

5.2 Test Mode

The Test Mode will test all the display functions.

1. Press both buttons together, and hold for more than 3 seconds, until 'rEd', 'Grn', or 'YEL' is shown on the display.
2. Press the HEADING button three times, until the LCD shows 'tEst'.
3. Press both buttons together to start to set Test Mode On, the current value, 'OFF', will be shown flashing.
4. Select Test Mode On by pressing either button on its own, the LCD will show 'ON' flashing.
5. Press both buttons together to start Test Mode.

If it is decided not to start Test Mode then press either button to change the LCD back to flashing 'OFF', then press both buttons to return to showing 'tEst'. Return to the main display by pressing the LOCK button twice to select the Calibration Mode End Screen, and then pressing both buttons together.

Test Mode

The display will go through six tests. To move on to each test, press the HEADING button. In order to leave test mode, press the LOCK button.

First the LCD will light all the segments and the pointer will return to the zero position. The LCD will then blank.

Pointer Test

The LCD will then show the software code version, and after a few seconds the pointer will start to move backwards and forwards through its whole movement. This will be repeated until a button is pressed.

LCD Segments Test

After the pointer test, the display will show 'tSt2', and start the LCD test. This will light every one of the segments on the LCD one by one. They will then be turned off one by one until they are all off again. This will be repeated until a button is pressed.

LCD Contrast Test

After the LCD Segment test, the display will show 'tSt3' and start to swap between the two LCD contrast levels, showing 'LCd' and the contrast level. This will continue until a button is pressed.

Lighting Test

After the LCD Contrast Test, the display will show 'tSt4' and start to cycle through the various lighting levels and colours. There are four red lighting levels (r8, r4, r2, r1), three green levels (G4, G2, G1) and three yellow levels (L4, L2, L1). This will continue until a button is pressed.

NMEA Input Test

After the lighting test, the display will show 'tSt5' and start to monitor its NMEA input. It will show 'IN' and a count of the successful inputs up to five, when it will automatically step onto the next test.

If the display is receiving NMEA data, the count should happen without any actions on the user's part. If the display is powered up on its own, then its NMEA input (White) may be connected to the 12V power (Red) five times to simulate an input.

NMEA Output Test

After the NMEA Input test, the display will show 'tSt6' and step onto the NMEA output test. If the display is connected to a Databox, then it will automatically transmit messages to the Databox and monitor the NMEA input for correct replies. This will count up from 1 to 5 while showing 'OUT'. (A failure here could be a wiring or Databox problem, however.) If the display is not on a Databox, then its NMEA Output (Brown) should be connected to the NMEA Input (White) and the display will transmit directly to itself.

After a successful test, the display will automatically step on to the next test.

Button Test

After the NMEA Output test, the display will show 'tSt7', then test the two buttons, prompting with the button number. After a successful test of both buttons, the display will automatically return to normal mode.

The buzzer should beep on every button test.

5.3 Fault Finding Chart

This chart assumes that the instrument is part of a Dataline-X instrument system. If it is connected to another instrument system then perform the equivalent checks on that system.

General Display and Communications Faults

<u>Condition</u>	<u>Probable Cause</u>	<u>Action</u>
All instruments have blank displays.	No 12V Power Supply.	<p>Check that the ships instrument system fuse(s) or circuit breaker(s) are not blown / tripped.</p> <p>Check the power supply wiring to the Databox.</p> <p>Check the 2.5A fuse inside the Databox. (This is the leftmost of the two fuses inside the Databox when it is viewed with the connectors at the lower edge, with the top cover removed. In order to remove the top cover to the Databox first remove the four screws in its corners.)</p> <p>Check the power supply wiring from the Databox to the instruments (the Red and Black 'Dataline' wires).</p> <p>Check for the Dataline-X instruments powering up, if not connected to the Databox, but directly to the power supply.</p> <p>Contact your dealer.</p>
One or more, but not all, instruments have blank displays.	There is no 12V power supply to the affected instrument (s).	<p>Check the power supply wiring to the affected instrument(s) (the Red and Black 'Dataline' wires). This is almost certainly the problem if more than one instrument is not functioning.</p> <p>Contact your dealer.</p>

<u>Condition</u>	<u>Probable Cause</u>	<u>Action</u>
<p>All instruments always show '----', with the pointers of analogue instruments at their zero positions.</p>	<p>No data is reaching any of the instruments.</p>	<p>Check that the battery voltage at the Databox Power Input terminals is greater than 10V.</p> <p>Check the signal wiring from the Databox to the instruments (the White and Green 'Dataline' wires). (If the lighting on any instrument can be controlled from another instrument then this is not the problem.)</p> <p>Contact your dealer.</p>
<p>One or more, but not all, instruments always show '----', with the pointers of analogue instruments at their zero positions.</p>	<p>No data is reaching the affected instrument(s).</p>	<p>Check the signal wiring to the affected instrument(s) (the White and Green 'Dataline' wires). This is almost certainly the problem if more than one instrument is affected. (If the lighting on any affected instrument can be controlled from another instrument then this is not the problem.)</p> <p>Contact your dealer.</p>
<p>All instruments show question marks on their display after they are used to set the lighting level, and the lighting level soon returns to Off, but other data is correct.</p> <p>Or:</p> <p>All instruments show question marks after setting any other data values.</p>	<p>The lighting level or other data is not reaching the Databox.</p>	<p>Check the return signal wiring to the Databox (the Brown 'Dataline' wire).</p> <p>Contact your dealer.</p>
<p>One or more instruments show question marks on their display after they are used to set the lighting level, and the lighting level soon returns to the previous level, but other data is correct, and other instruments can set the lighting level correctly.</p> <p>Or:</p> <p>One or more instruments show question marks after setting any other data values.</p>	<p>The lighting level or other data is not reaching the Databox from the affected instrument(s).</p>	<p>Check the return signal wiring from the affected instruments to the Databox (the Brown 'Dataline' wire).</p> <p>Contact your dealer.</p>

For Standalone Displays - Connected to a Heading Sensor or Autopilot

<u>Condition</u>	<u>Probable Cause</u>	<u>Action</u>
The LCD display is blank and the pointer does not move.	No 12V power supply.	Check the fuse(s) and / or circuit breaker(s). Check the power supply wiring.
No Displays.	No information from the heading sensor.	Check that the heading sensor is turned on. Check the heading sensor NMEA output specification against the COMPASS input specification. (Appendix A). Check the heading sensor power supply wiring. Check the signal wiring from the heading sensor to COMPASS. Check that the heading sensor is driving other remote displays correctly. Contact your dealer.
No Autopilot Display, even though the Heading and Locked Course Displays are working.	Data not available from the Autopilot.	Check the Autopilot NMEA output specification against the COMPASS input specification. (Appendix A). Contact your dealer.
All headings are incorrect, by the same amount. Note: When checking a Compass ensure that the check is against a deviated magnetic card compass, or against magnetic bearings, or against a good hand held compass held well away from any magnetic or ferrous objects.	Heading sensor not aligned correctly.	RFC250 Sensor: Loosen the fixings and rotate the sensor so that the arrow is facing directly forwards. Tighten the fixings again. Dataline Sensor: Check that the sensor is mounted on a bulkhead that faces exactly forwards. If so then contact your dealer. Other Sensor: Consult the manufacturers instructions.

<p>Some or all headings are incorrect, by different amounts.</p> <p>Note: When checking a Compass ensure that the check is against a deviated magnetic card compass, or against magnetic bearings, or against a good hand held compass held well away from any magnetic or ferrous objects.</p>	<p>Heading sensor not auto deviation compensated.</p> <p>Magnetic or ferrous objects moved into or away from the vicinity of the heading sensor.</p> <p>The location of the sensor is unsuitable.</p>	<p>Re-calibrate the sensor.</p> <p>Check for possible objects that may affect the sensor, e.g. a portable radio. If the change is permanent then re-calibrate the sensor.</p> <p>Check that the location of the sensor is suitable, if not then re-site it.</p>
-----------------------------------------------------------------------------------------------------------------------------------------------------------------------------------------------------------------------------------------------------------------------------------------------------	-------------------------------------------------------------------------------------------------------------------------------------------------------------------------------------------------------	-----------------------------------------------------------------------------------------------------------------------------------------------------------------------------------------------------------------------------------------------------------------

For Standalone Displays

<u>Condition</u>	<u>Probable Cause</u>	<u>Action</u>
<p>The LCD display is blank and the pointer does not move.</p>	<p>No 12V power supply.</p>	<p>Check the fuse(s) and / or circuit breaker(s).</p> <p>Check the power supply wiring.</p>

Other Faults

<u>Condition</u>	<u>Probable Cause</u>	<u>Action</u>
<p>The external alarm does not sound.</p>	<p>The alarm is not turned on, or the values are not as desired.</p> <p>The external alarm sounder is not connected to the Databox properly.</p> <p>The external alarm sounder is not suitable.</p> <p>The external alarm sounder is not working.</p>	<p>Check that the desired alarm is turned on and has the correct value.</p> <p>Check the alarms' connections to the Databox.</p> <p>Check that the alarm sounder does not require more current or a higher voltage than is available.</p> <p>Check with the alarm sounder driven directly from a suitable power supply.</p> <p>Contact your dealer.</p>
<p>There are missing Engine Hour or Battery Voltage displays, or the Engine Hour counts don't work, or these displays always show '----'.</p>	<p>The engine hour / sat nav set ups are incorrect.</p> <p>The engine hour / battery voltage inputs are not connected to the Databox properly.</p>	<p>Check the set up, and correct if necessary. (Using another instrument.)</p> <p>Check the connections to the Databox, and correct if necessary.</p> <p>Check that the engine inputs are active when the engines are turned on.</p> <p>Contact your dealer.</p>

Condensation forms inside the instrument.	Slight internal moisture.	Turn the lights to Level 7 and leave on until cleared.
-------------------------------------------	---------------------------	--------------------------------------------------------

CONTENTS

- 6.1 General Maintenance
- 6.2 Annual Maintenance
- 6.3 Removal of Instrument
- 6.4 Return for Service

6.1 General Maintenance

The instrument head will require no maintenance apart from occasional cleaning. Do this using fresh water and a mild soap solution (not a detergent).

CAUTION

DO NOT USE ANY ABRASIVES, CHEMICAL CLEANERS, PETROL OR DIESEL TO CLEAN THIS UNIT.

6.2 Annual Maintenance

1. Check all connections to the instrument and, if necessary, cover with silicone grease or petroleum jelly.

6.3 Removal of Instrument

1. If rear access is possible unplug the Dataplug connectors from the rear of the instrument. If the connection needs to be made up then the two wires may be joined using one of the connectors as a terminal block.
2. Remove the outer cover. This can be done by squeezing the instrument sides between finger and thumb and applying an upward pressure. At the same time, place a flat-bladed screwdriver between the bulkhead (or panel) and the cover, and carefully rotate.
3. Remove the cover and the four corner fixing screws.
4. Pull the instrument free from the surface, being careful not to strain the wiring if the connectors have not yet been removed.

5. If they are not yet removed, unplug the Dataplug connectors from the rear of the case, and make up the cable if necessary.

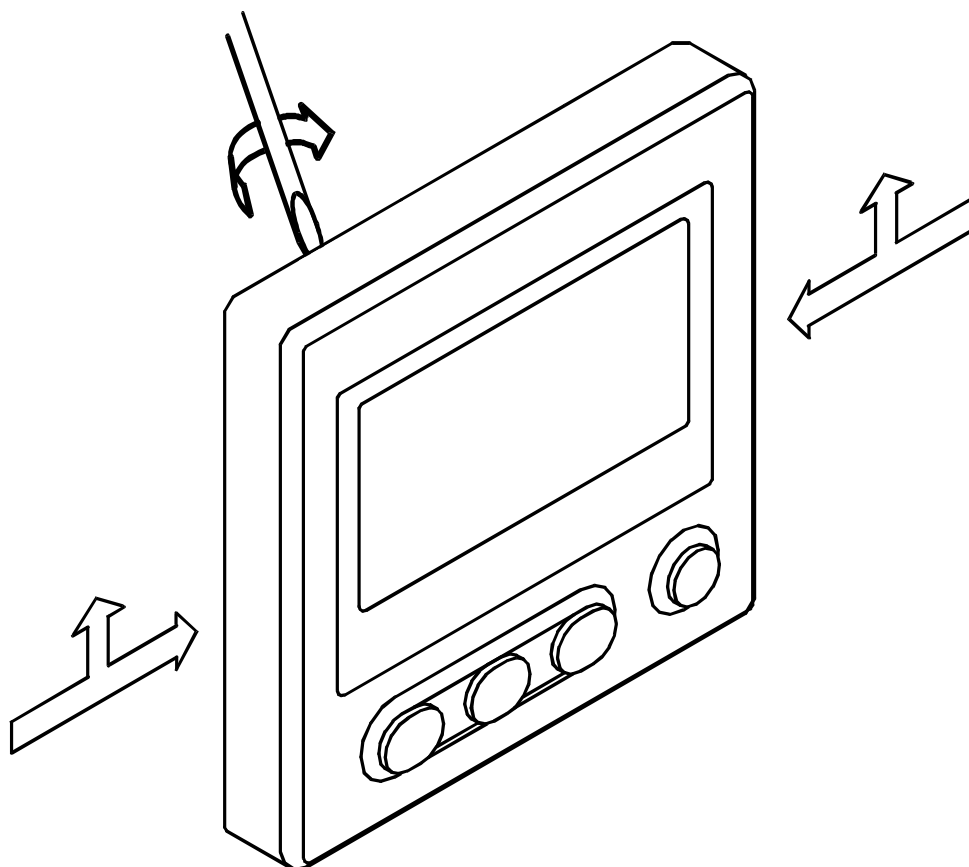

Figure 6.1 - Removal of Instrument

6.4 Return for Service

Please ensure that an instrument that is believed to be faulty is correctly installed, the wiring is in good condition and correct, that all connections are secure, and that a 12V supply is present at its power input terminals.

Should the unit have to be returned to your dealer, adequate packing must be used. Please ensure that your name, telephone number, return address, a clear fault description, and if possible a copy of the receipt of purchase are included with any returned equipment. Simrad Ltd. and their representatives are not responsible for any equipment lost in transit.

Please quote the instrument's serial number in all correspondence. This may be found on the rear of the instrument.

—

The NMEA 0183 messages that are received by the COMPASS display are as below:

HDM
HDT = Heading
VHW

RMA = Magnetic Variation
RMC